

CONERO

Kleiderlift / Wardrobe lift / Tringle d'armoire escamotable

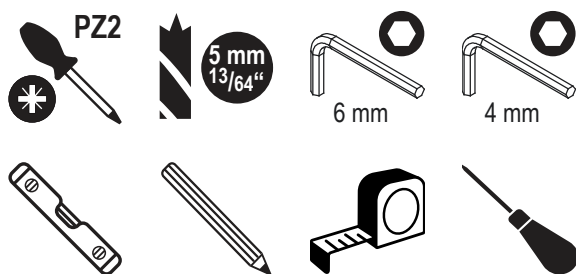

KESSEBÖHMER

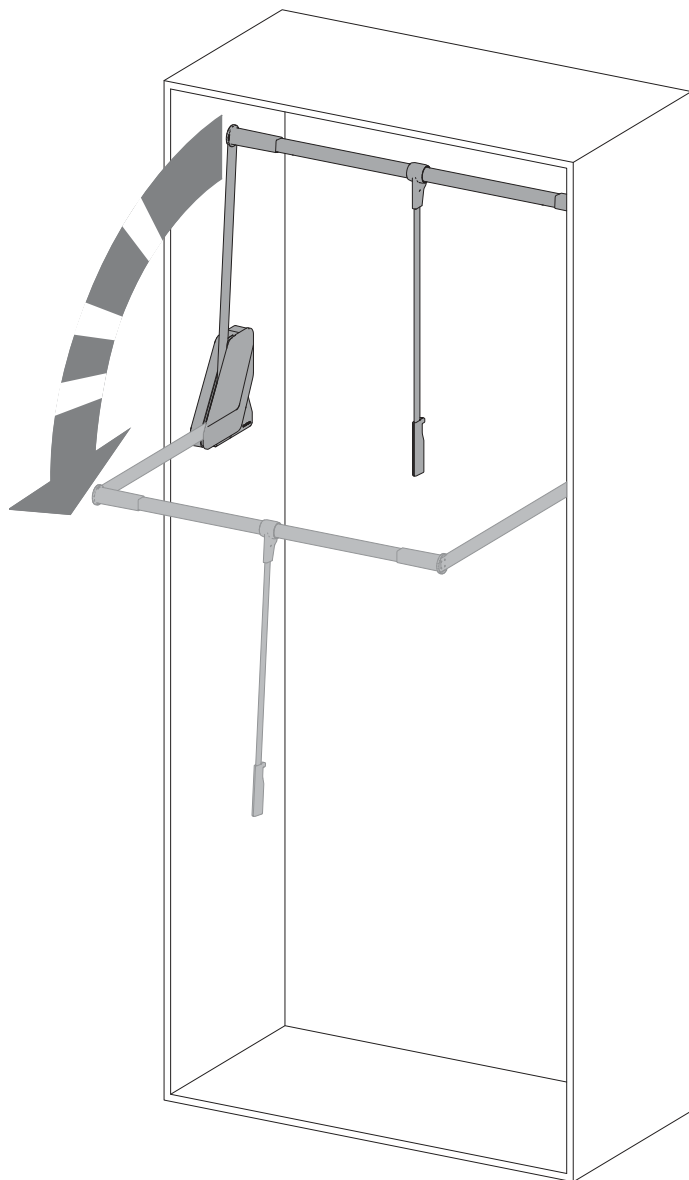

<http://support.kesseboehmer.de>





DE Die Gewichts- und Beladungsangaben gelten als Maximalwert und sind abhängig von den gewählten Schrankmaterialien (ein verwindungssteifes Vollmaterial - z.B. Massivholz, Spanplatte – ist zu wählen) und der Schrankkonstruktion und können dementsprechend variieren! Es wird davon ausgegangen, dass geeignete Verbindungs- und ggf. Konstruktionshilfsmittel (z.B. Stützen) eingesetzt werden. Eine verbindliche Beladungsangabe obliegt dem Verarbeiter!

EN The weight and load specifications are given as maximum values and depend on the selected cupboard materials (a warp resistant solid material, such as solid wood or chipboard, should be chosen) and cupboard design so they may vary accordingly! It is assumed that suitable fasteners and, if required, construction hardware (e. g. supports) will be used. The fabricator is responsible for binding load specifications!

FR Les indications relatives au poids et à la charge servent de valeurs maximales, dépendent des matériaux choisis pour l'armoire et sa structure (choisir un matériau résistant à la torsion, p. ex. bois massif, panneau d'agglomérés), et peuvent varier en conséquence! On suppose que des éléments de liaison et de structure appropriés (p. ex. des supports) sont utilisés. Le responsable de la transformation du meuble est tenu de définir lui-même les valeurs de la charge!

IT Le indicazioni di peso e carico sono valori massimi dipendono dal tipo di materiale (scegliere un materiale resistente alla torsione - p.e. legno massiccio, compensato) e dalla struttura sceti per il mobile e possono pertanto essere soggetti a variazioni! Si presuppone l'utilizzo di strumenti di collegamento e, eventualmente, di costruzione appropriati (p.e. supporti). Un'indicazione vincolante del carico spetta a colui che esegue il montaggio!

ES Los datos sobre el peso y la capacidad de carga son valores máximos y pueden variar en función de los materiales del armario (preferiblemente un material resistente a la torsión, como por ejemplo madera maciza o aglomerada) y del tipo de diseño elegido. Es de suponer que se utilizarán los elementos de montaje adecuados (p. ej. cuñas). ¡El montador es la única persona competente para asegurar la capacidad de carga!

PT Os dados relativos ao peso e carga são valores máximos e dependem dos materiais do armário escolhidos (deve optar-se por um material resistente a deformações, p. ex., madeira maciça, contaplacado) e da construção do armário, podendo variar consoante os mesmos! Assume-se que são empregues os auxiliares de união e de construção (p. ex., suportes) adequados. Compete ao fornecedor a indicação vinculativa da carga!

HE המידע לגבי המשקל והעומס הינו ערך מרבי ותלוי בחומרי הארון שנבחרו (יש לבחור חומר עמיד לפיתול - כגון עץ מלא, סיביט) ובמבנה הארון, ועשוי להשתנות בהתאם! ההנחה היא כי נעשה שימוש בחיבורים מתאימים ובמידת הצורך, בעזרי בנייה (כגון תומכים). המעבד אחראי לספק מידע אודות עמידות לכיפוף בעומס!

FI Painoa ja kuormitusta koskevat tiedot ovat maksimiarvoja. Tiedot riippuvat kaapin materiaalista (tulisi valita jäykkä materiaali, esim. massiivpuu tai lastulevy) ja rakenteesta ja voivat siten vastaavasti vaihdella! Edellytämme, että kaappien asennuksessa käytetään sopivia kiinnittimiä ja muita apuvälineitä (esim tukia) Asentajan tehtävänä on varmistaa että kuormitustiedot ovat oikeat!

DA Vægt- og belastningsangivelser er maksimale værdier. De afhænger af de valgte skabsmaterialer (et krumningsstift materiale - f.eks. massivt træ, spåplade - bør vælges) og den valgte skabskonstruktion og kan derfor variere. Det forudsættes, at der anvendes egnede forbindelses- og evt. konstruktionshjælpe midler (f.eks. afstivninger). En bindende belastningsangivelse må indhentes hos den, der udfører arbejdet!

CS Uvedené hmotnosti a nosnosti platí jako maximální hodnoty a závisí na zvolených materiálech skříně (volte torzně tuhý materiál - např. masivní dřevo, dřevotřískové desky) a konstrukci skříně, a mohou se proto odpovídajícím způsobem lišit! Předpokládá se použití vhodných spojovacích prvků a příp. dalších konstrukčních prostředků (např. vzpěr). Stanovení závazné informace o nosnosti přísluší zpracovateli!

PL Podane ciężary i dane do załadunku to wartości maksymalne, i zależą od wybranych materiałów (należy wybrać materiał odporny na zwichrowanie - np. lite drewno, płyta wiórowa) i konstrukcji szafy, mogą się więc różnić! Zakłada się, że zostaną zastosowane odpowiednie elementy połączeniowe i ew. pomocnicze elementy konstrukcyjne (np. podpory). Określenie wiążących danych do przeladunku jest obowiązkiem przetwórcy!

RU Приведены данные относительно максимальных масс и нагрузок; они зависят от выбранных материалов (следует выбирать материалы, жесткие на скручивание, например, массивную древесину, ДСП) и конструкции шкафа и потому могут варьироваться! Мы исходим из того, что используются соответствующие предъявляемым требованиям крепежные и вспомогательные средства (например, опоры). Обязательные сведения о допустимых нагрузках должен предоставить переработчик!

TR Ağırılık ve yüklenme verileri maksimum değerler olup seçilen dolap malzemeleri (burkulumaya dayanıklı malzeme (örn. masif ağaç, sunta - seçilmelidir) ve dolap konstrüksiyonuna bağlı olarak farklılık gösterebilir! Uygun özelliklere sahip bağlantı elemanları ve gerekirse yardımcı konstrüksiyon gereçlerinin (örn. destekler) kullanılması varsayılmaktadır. Bağlayıcı yük verilerinin temin edilmesi işleyen kişinin sorumluluğundadır!

BG За теглото и натоварването се приема максималната стойност и тя зависи от избраните материали за шкафа (трябва да се избере устойчив на усукване материал, напр. масивно дърво, дървесна плоскост) и конструкцията и могат да варират! Предполага се, че се използват подходящи съединителни и ако е необходимо, помощни строителни средства (напр. опори). За задължителната информация за натоварването е отговорна фирмата производител!

HU A súlyra és a terhelésre vonatkozó adatok maximum értékek, és függnek a választott szekrényanyagoktól (nagy torziós merevségű anyagot, pl. tömör fát, forgácslemezt kell választani) és annak megfelelően változóak lehetnek! Abból indulunk ki, hogy megfelelő kötőanyagokat és adott esetben konstrukciós segédesszközöket (pl. támaszokat) alkalmaznak. Kötelező érvényű terhelési adat a feldolgozó felelőssége!

SR Podaci o težini i opterećenju predstavljaju maksimalne vrednosti i zavise od izabranih materijala (treba odabrati materijal otporan na uvijanje - npr. masivno drvo, iverica) i konstrukcije ormana i mogu se u skladu s tim razlikovati! Pretpostavlja se da se koriste odgovarajuća pomoćna sredstva za povezivanje i, ako je potrebno, građevinska pomagala (npr. podupirači). Proizvođač je obavezan da dostavi odgovarajuće podatke o opterećenju!

EL Τα δεδομένα βάρους και φόρτισης ισχύουν ως μέγιστες τιμές και εξαρτώνται από τα επιλεγμένα υλικά του ντουλαπιού (θα πρέπει να επιλεγεί υλικό ανθεκτικό στη στρέψη – π.χ. μασίφ ξύλο, μοριοσανίδα) και την κατασκευή του ντουλαπιού και ενδέχεται να διαφέρουν ανάλογα! Πρέπει να χρησιμοποιούνται κατάλληλα συνδετικά και, εάν είναι απαραίτητο, κατασκευαστικά βοηθήματα (π.χ. στηρίγματα). Η δεσμευτική προδιαγραφή φόρτισης είναι ευθύνη του κατασκευαστή!

AR تسري بيانات الوزن والحمولة باعتبارها القيم القصوى، وهي ترتبط بمواد الخزانة المختارة (يجب اختيار مادة مقاومة للالتواء، مثل الخشب الصلب، أو ألواح خشب مضغوطة) وهيكلة الخزانة ويمكن أن تختلف وفقاً لذلك! من المفترض أنه قد تم استخدام مواد ربط وإنشاء مناسبة (مثل الدعائم). القائم على المعالجة هو المسؤول عن مراعاة بيانات التحميل المؤمنة!

JA 重量と積載仕様は最大値であり、選択した戸棚の素材(無垢材、合板などの座屈耐性のある素材を選べます)と構造に従って異なります。適した留め具や、必要な場合は(支持器具などの)建設器具を使用するものとします。義務的な積載仕様は製作者の責任によります。

CN 重量和载荷数据仅为最大值，而且可能根据所选橱柜材质（应当选择防屈曲材料，例如：实木或硬纸板）和橱柜结构有所不同！因此需要使用适当的连接材料和结构辅助工具（例如支架）。具有合同效力的载重数据应当由施工方提供。

CONERO

Kleiderlift / Wardrobe lift / Tringle d'armoire escamotable

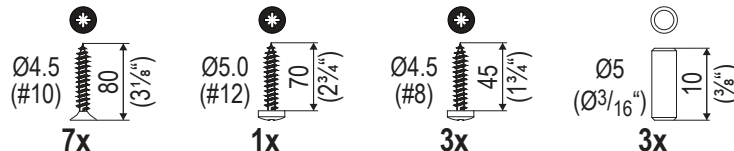
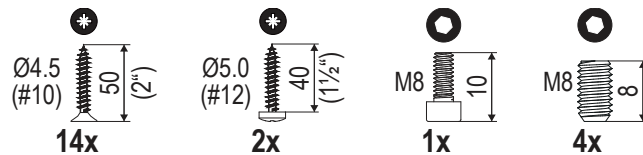
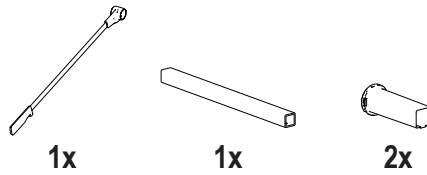
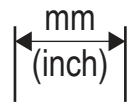
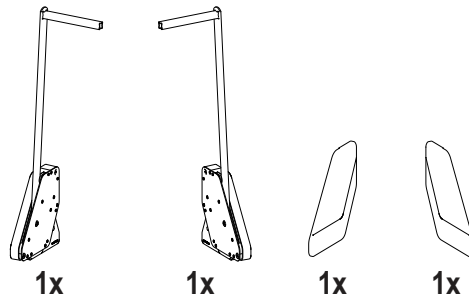

DE Die technischen Darstellungen und Maßangaben – auch bei Abbildungen und Zeichnungen – sind unverbindlich. Konstruktionsverbesserungen sind vorbehalten! **EN** Technical information and stated dimensions (including in illustrations and drawings) must not be regarded as binding. Design subject to improvement without notice! **FR** Les visuels techniques et dimensions – y compris les schémas et les illustrations – ne sont pas contractuelles. Sous réserve d'évolutions techniques! **IT** Le rappresentazioni tecniche e le indicazioni delle dimensioni – anche nelle figure e nei disegni – non sono vincolanti. Con riserva di miglioramenti di progettazione! **ES** Las imágenes técnicas y las indicaciones de medidas – también en imágenes y dibujos – no son vinculantes. Queda reservado el derecho de realizar mejoras en el diseño! **PT** Representações técnicas e dimensões – mesmo em ilustrações e desenhos – não são vinculativas. Reservado o direito a melhorias construtivas! **HE** כל התרשימים הטכניים והמידות - אף לגבי איורים ותכניות - הנם בלתי מחייבים. זכות לשוניים ושיפורים מבניים שמורה ליצרן! **FI** Tekniset piirroksset ja mitat – myös kuvissa ja piirroksissa olevat – ovat sitoumuksetta. Oikeus rakennetta parantaviin muutoksiin pidätetään! **DA** De tekniske illustrationer og målangivelser - også på illustrationer og tegninger - er ikke bindende. Forbehold for designforbedringer! **CS** Technické popisy a rozměry, jakož i obrázky a výkresy, jsou nezávazné. Vyrazujeme si právo na změny konstrukce! **PL** Prezentacje techniczne i wymiary – także na ilustracjach i rysunkach – nie są wiążące. Udoskonalenia konstrukcyjne są zastrzeżone! **RU** Иллюстрации технических деталей и указанные размеры, в том числе на рисунках и чертежах, являются ориентировочными. Компания оставляет за собой право на усовершенствование конструкции! **TR** Teknik sunum ve ölçü bilgileri (resim ve çizimlerde de) yasal olarak bağlayıcı değildir. Yapısal geliştirmeler uyarı hakkı saklıdır! **BG** Техническото представяне и размерите, включително при изображенията и чертежите, са необвързващи. Запазваме си правото на конструктивни подобрения! **HU** A műszaki ábrázolások és méretadatok – ábránál és rajzoknál sem – nem kötelező érvényűek. A konstrukciós javítások joga fenntartva! **SR** Tehničke ilustracije i dimenzije - uključujući ilustracije i crteže - nisu obavezujući. Dizajn poboljšanja su rezervisana! **EL** Τα τεχνικά σχήματα και οι διαστάσεις – ακόμα και σε απεικονίσεις και σχέδια – δεν είναι δεσμευτικά. Με την επιφύλαξη τεχνικών βελτιώσεων! **AR** الرسوم التوضيحية والأبعاد الفنية - بما في ذلك الرسوم التوضيحية والرسومات - ليست إلزامية. الحق محفوظ في إجراء تحسينات هيكلية! **JA** 技術情報および記載されている寸法(イラストや図面を含む)は、拘束的のあるものと見なされません。デザインは予告なしに改善されることがあります。 **CN** 技术说明和规格, 包括插图和图纸均不具约束力。保留改进设计的权利!

CONERO

Kleiderlift / Wardrobe lift / Tringle d'armoire escamotable



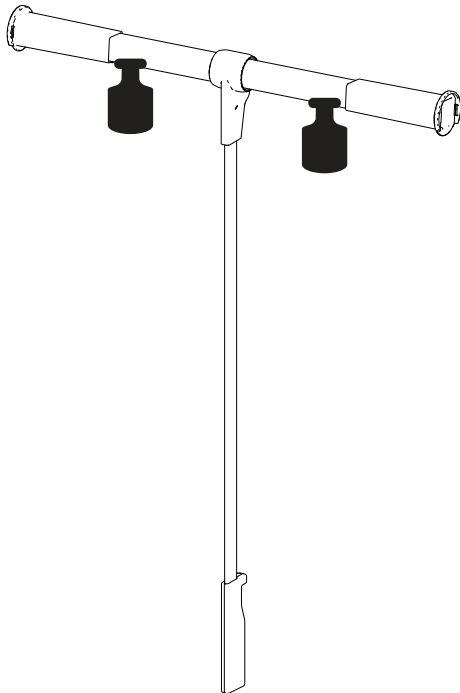

i

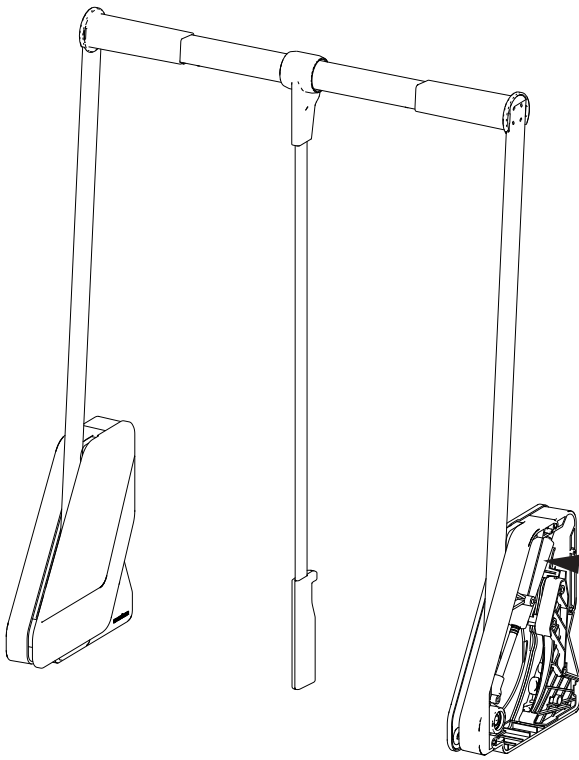

=  max.
12 kg
26,5 lbs



+  max.
12 kg
26,5 lbs =  max.
17,5 kg
38,5 lbs

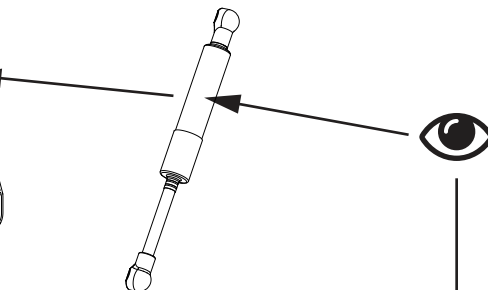

 **KESSEBÖHMER**
LIFT-O-MAT
HOHER DRUCK,
NICHT OEFFNEN, NICHT ERHITZEN **360N**

=  max.
12 kg
26,5 lbs

CONERO

Kleiderlift / Wardrobe lift / Tringle d'armoire escamotable



i

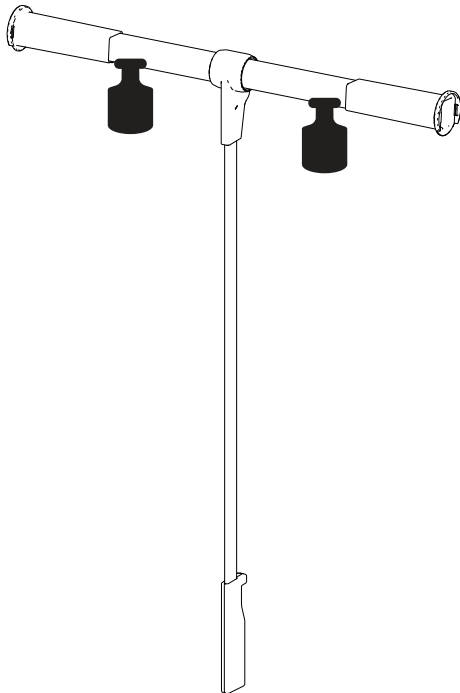

=  max.
15 kg
33 lbs

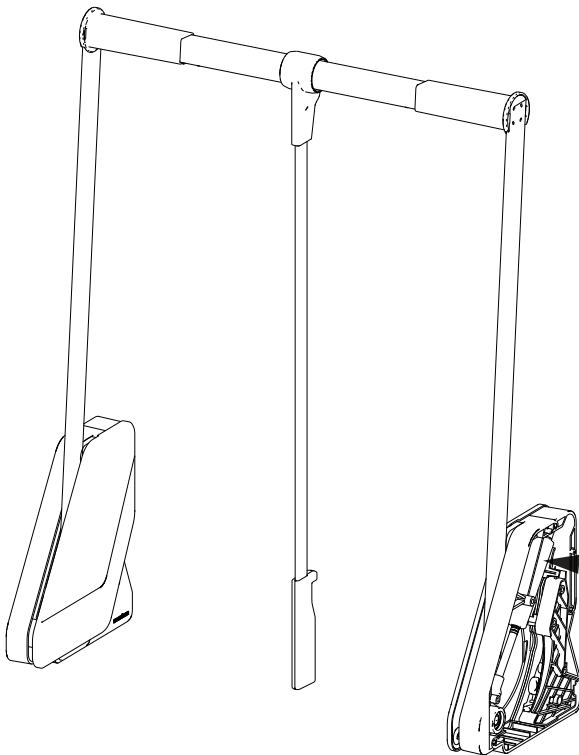

+  max.
15 kg
33 lbs =  max.
20,5 kg
45,2 lbs

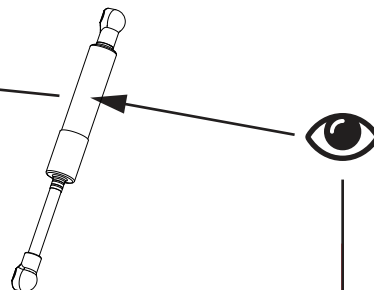

 **KESSEBÖHMER**
LIFT-O-MAT
HOHER DRUCK, **580N**
NICHT OEFFNEN, NICHT ERHITZEN

=  max.
15 kg
33 lbs

CONERO

Kleiderlift / Wardrobe lift / Tringle d'armoire escamotable



1

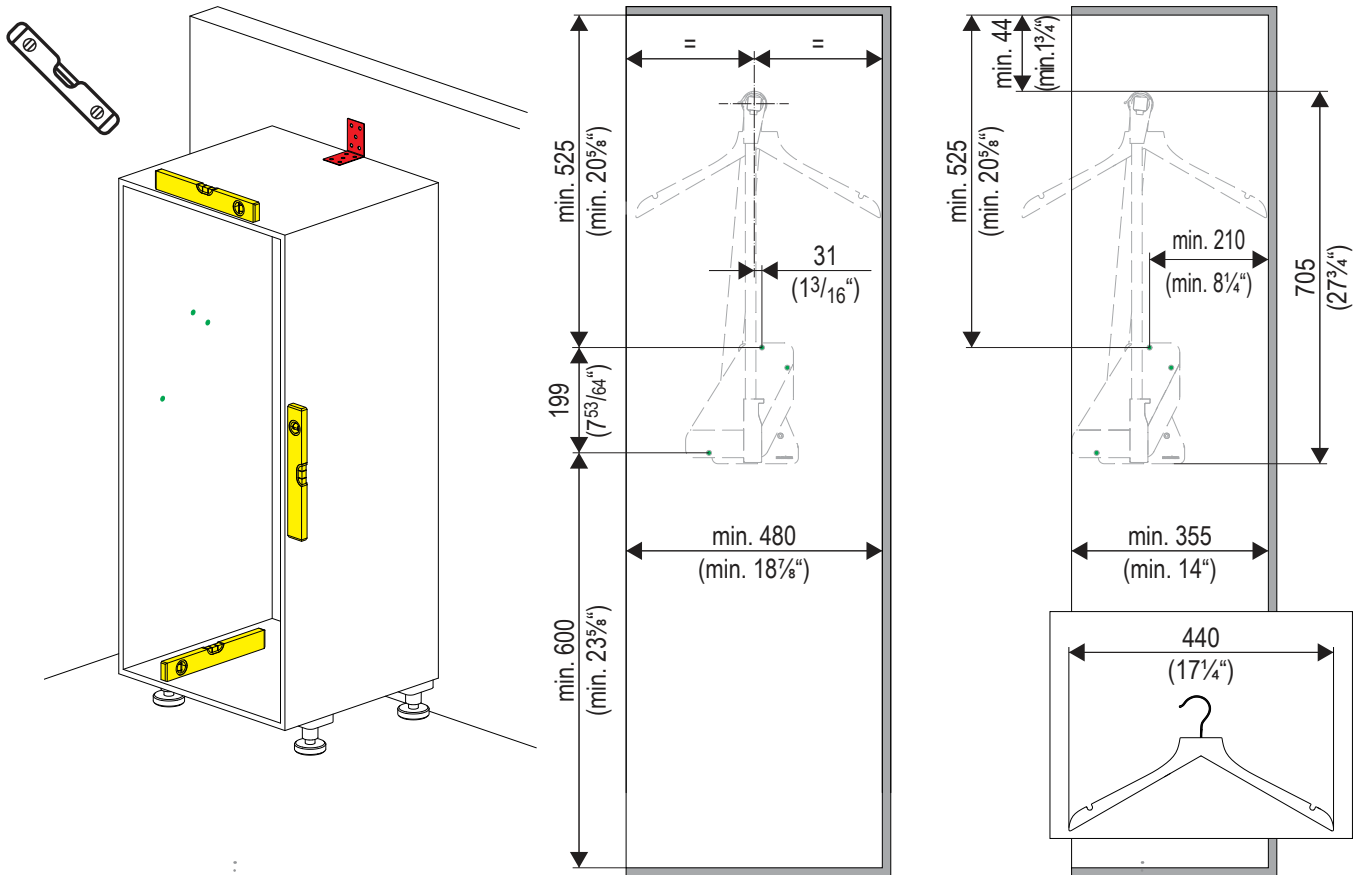

2

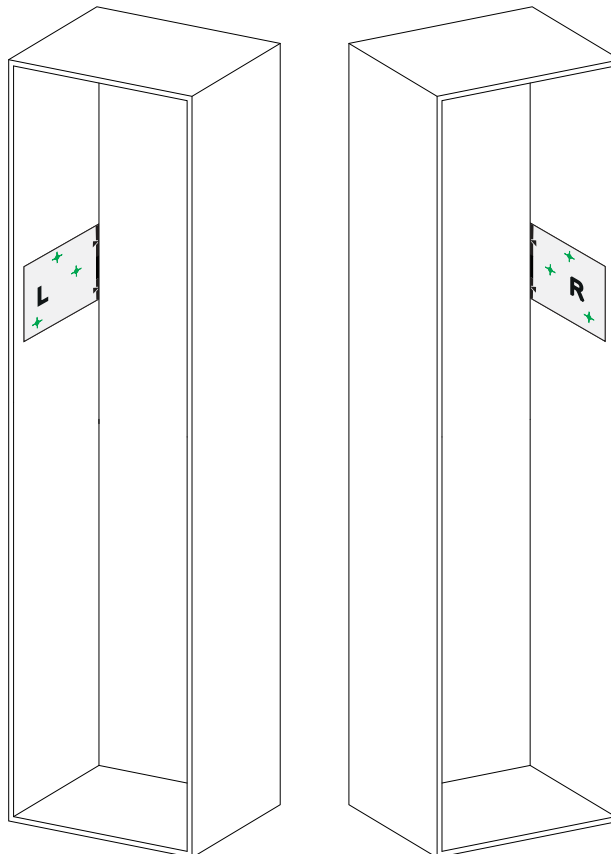

CONERO

Kleiderlift / Wardrobe lift / Tringle d'armoire escamotable



3

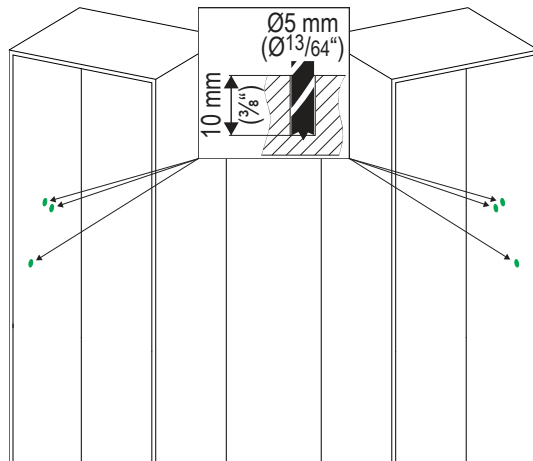

4

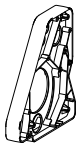

1 - 2x

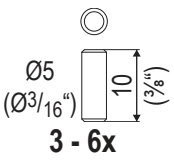
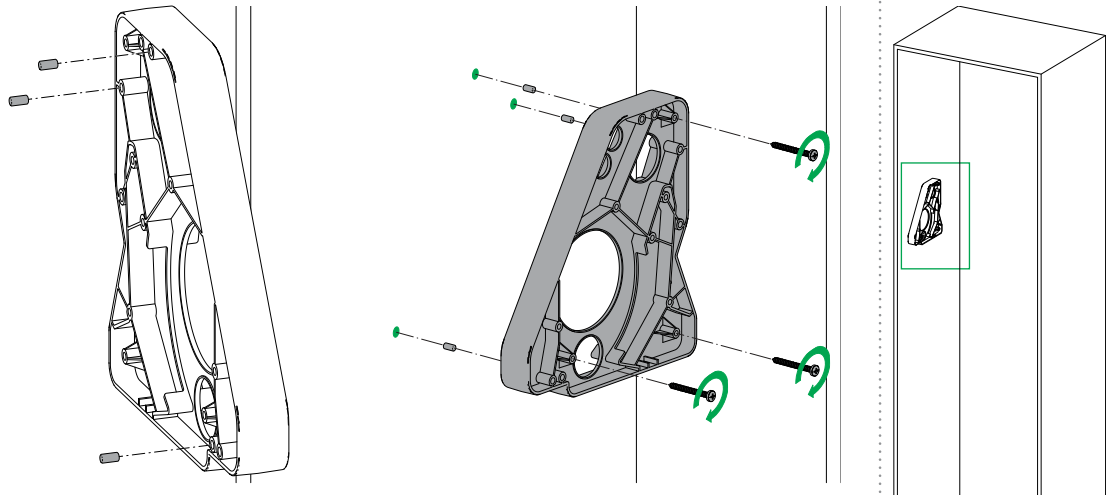

3 - 6x

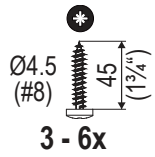

3 - 6x



PZ2

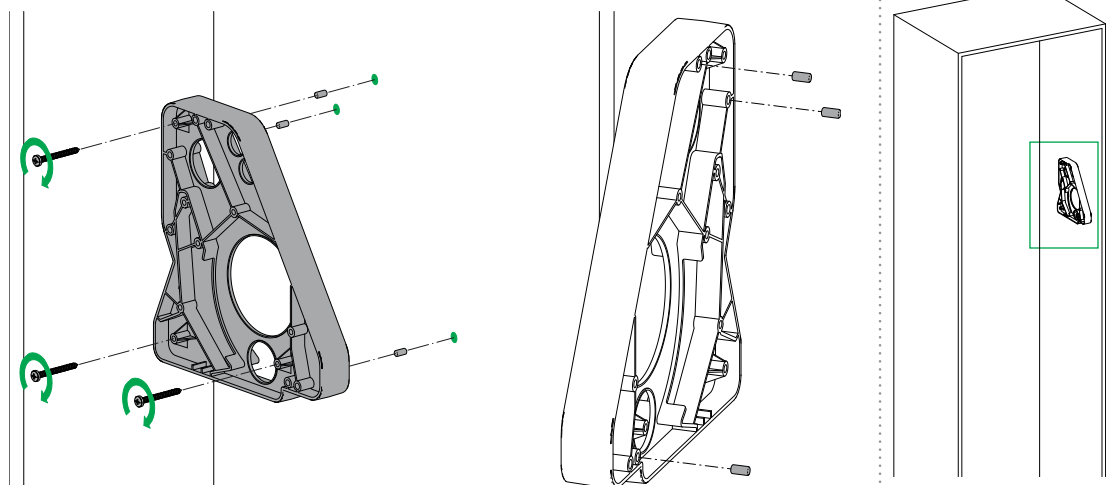

CONERO

Kleiderlift / Wardrobe lift / Tringle d'armoire escamotable



5



1x



1x



2x

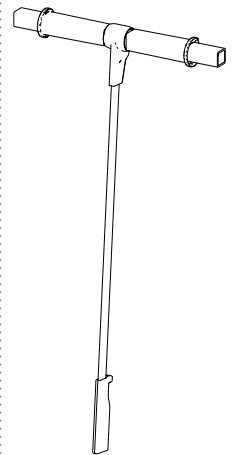
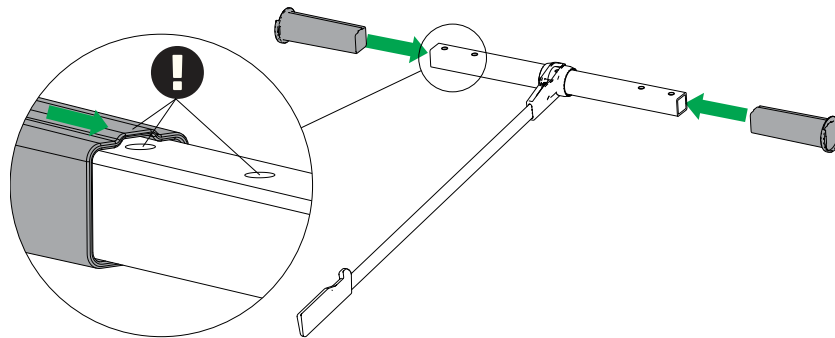
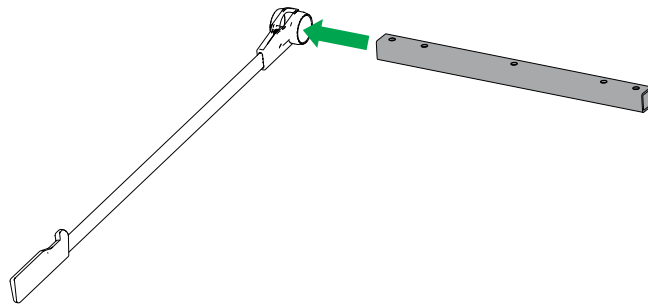

5.1

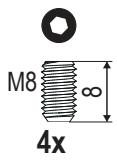

4x



4 mm

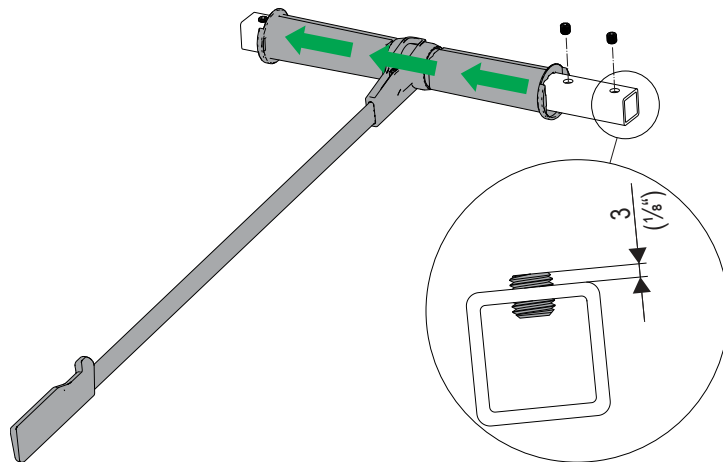
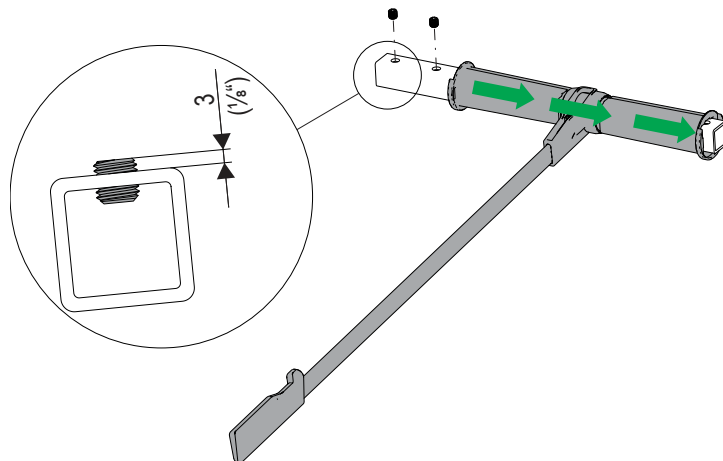

CONERO

Kleiderlift / Wardrobe lift / Tringle d'armoire escamotable



6

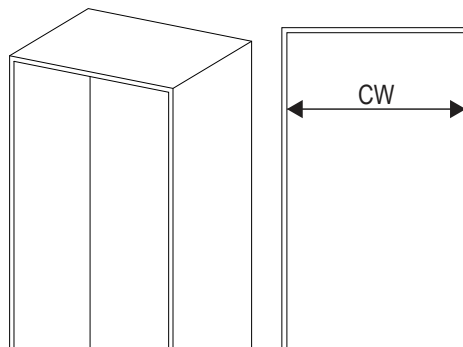
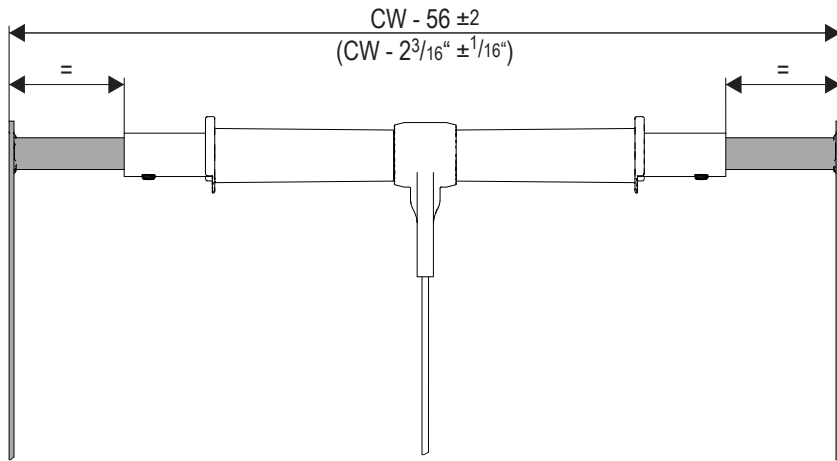
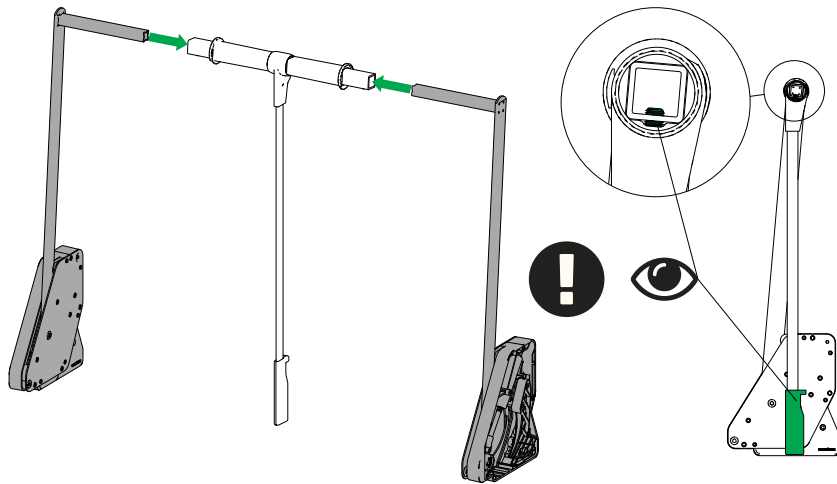
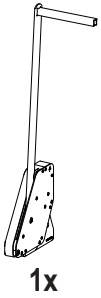

CONERO

Kleiderlift / Wardrobe lift / Tringle d'armoire escamotable



6.1

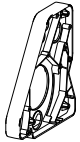

1 - 2x

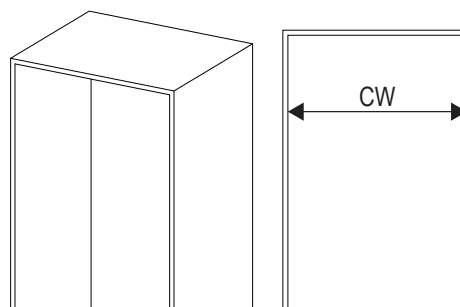
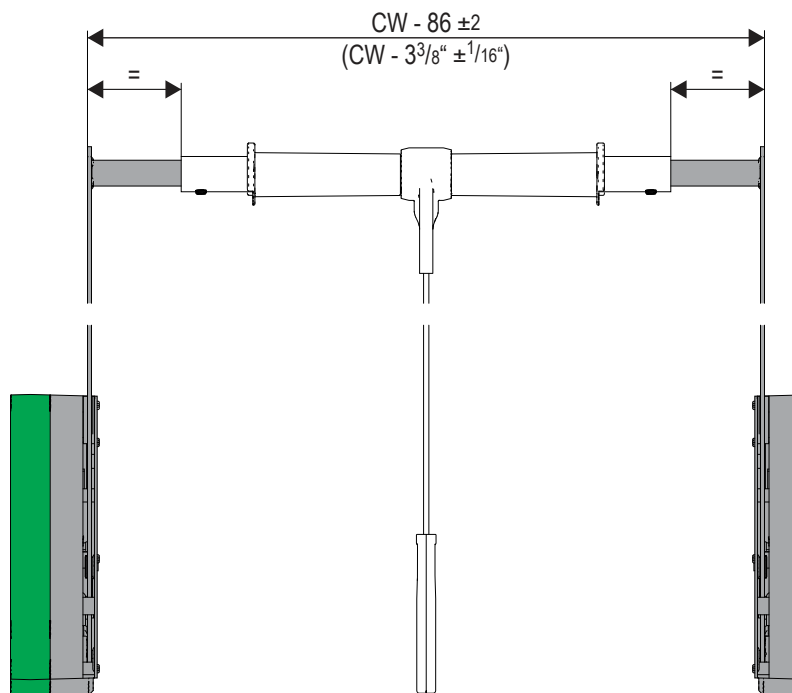
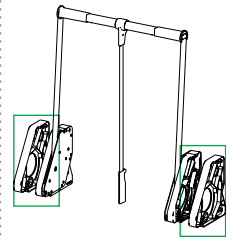
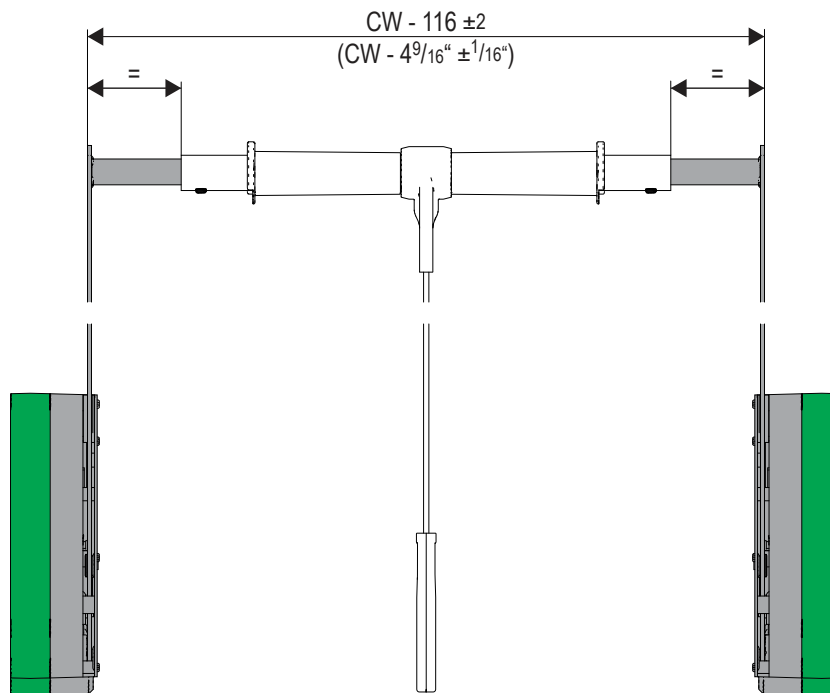

CONERO

Kleiderlift / Wardrobe lift / Tringle d'armoire escamotable



6.2



4 mm

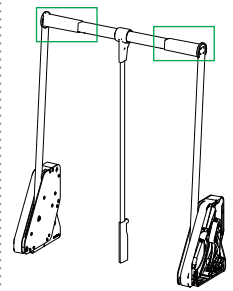
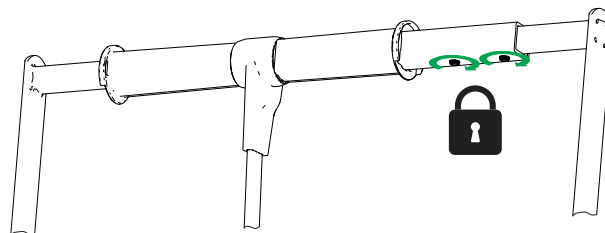
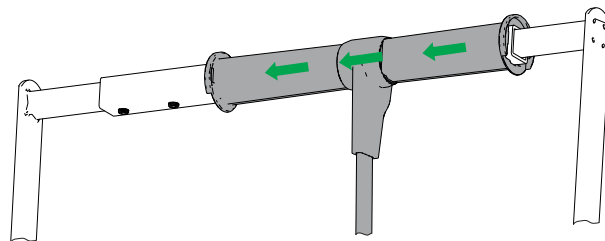
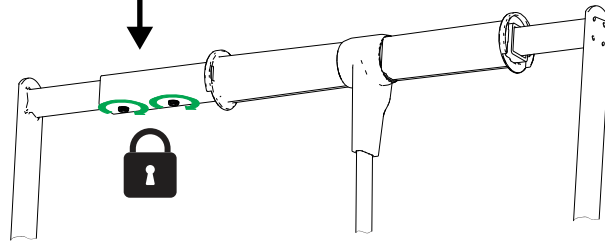
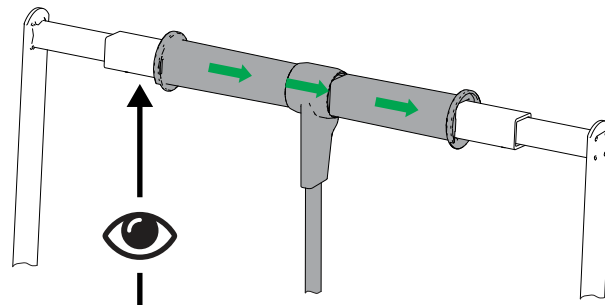

CONERO

Kleiderlift / Wardrobe lift / Tringle d'armoire escamotable



6.3

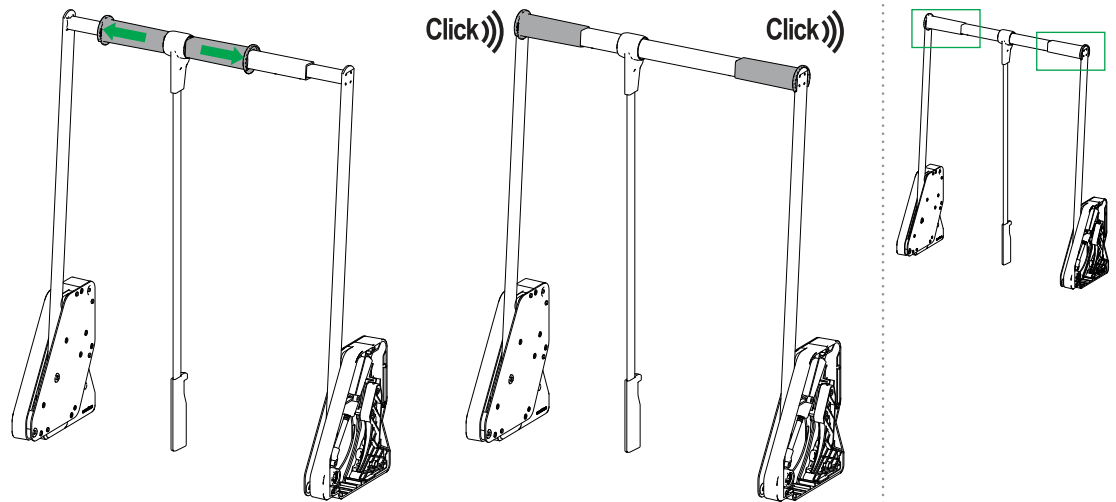

7

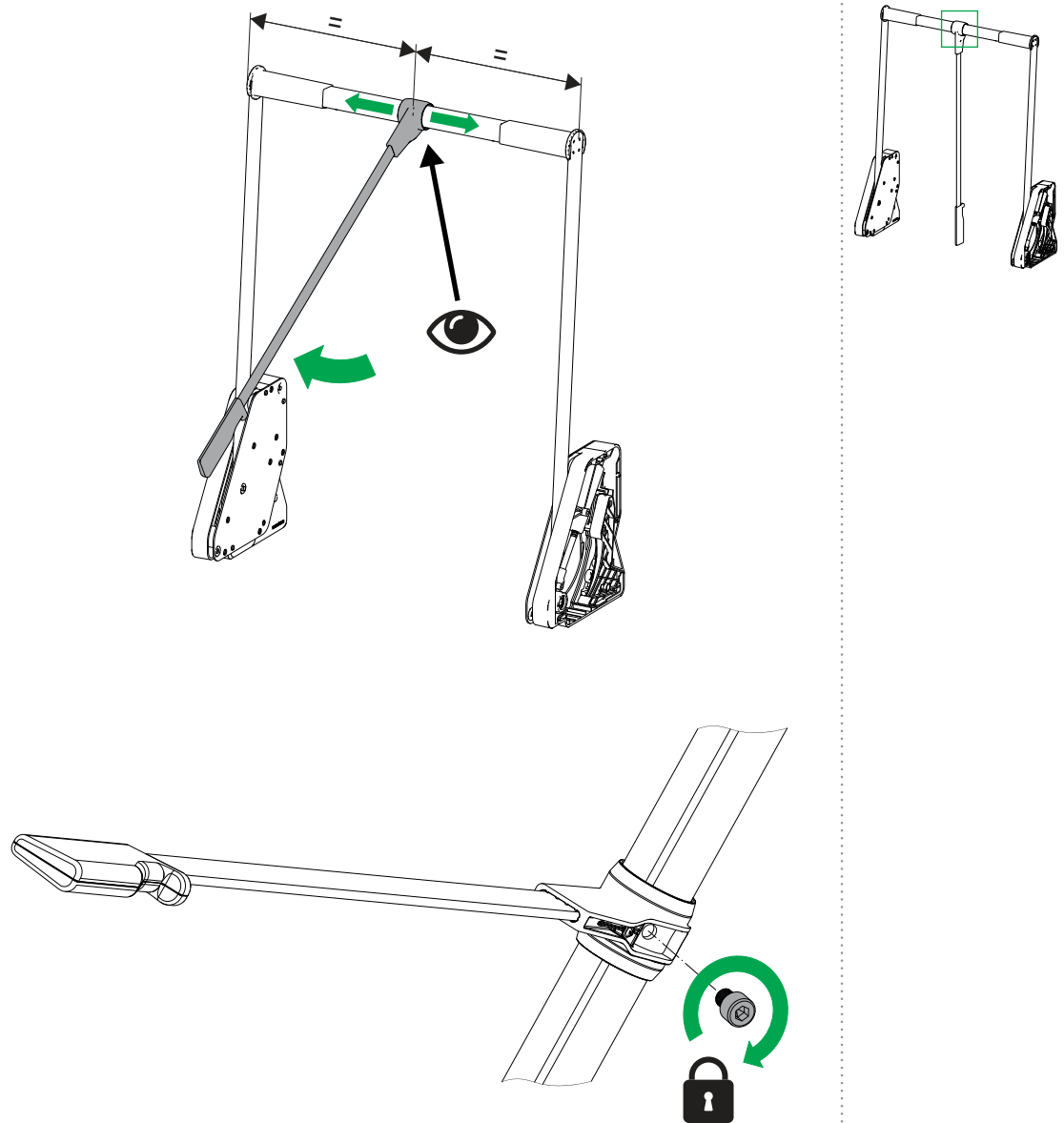
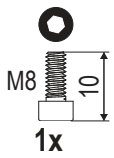

CONERO

Kleiderlift / Wardrobe lift / Tringle d'armoire escamotable



8

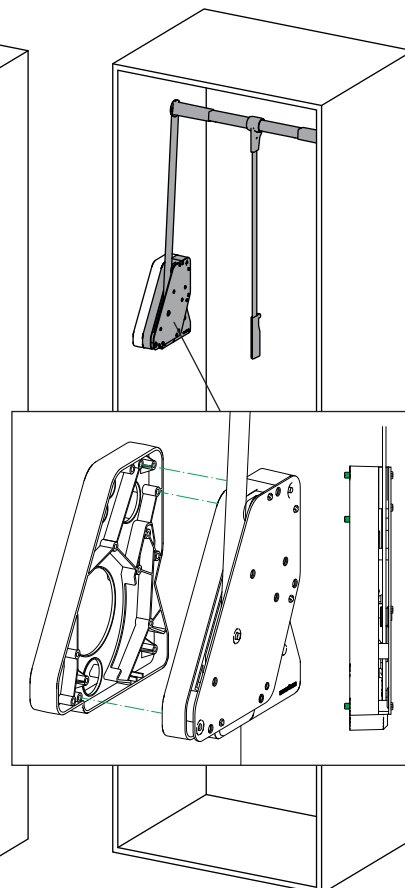
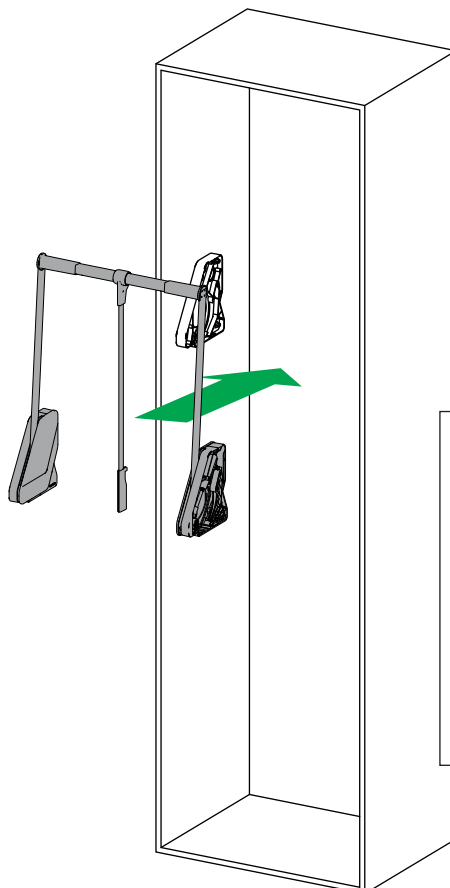
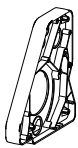
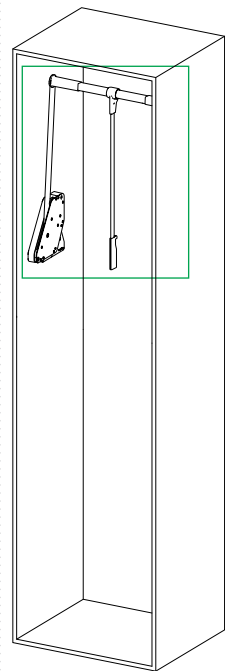
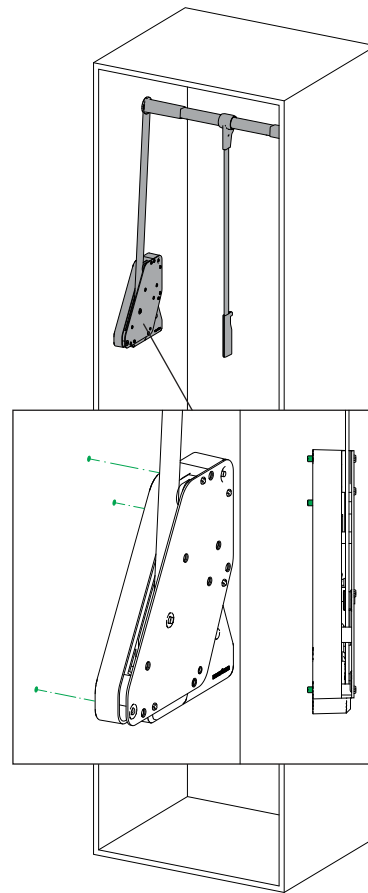
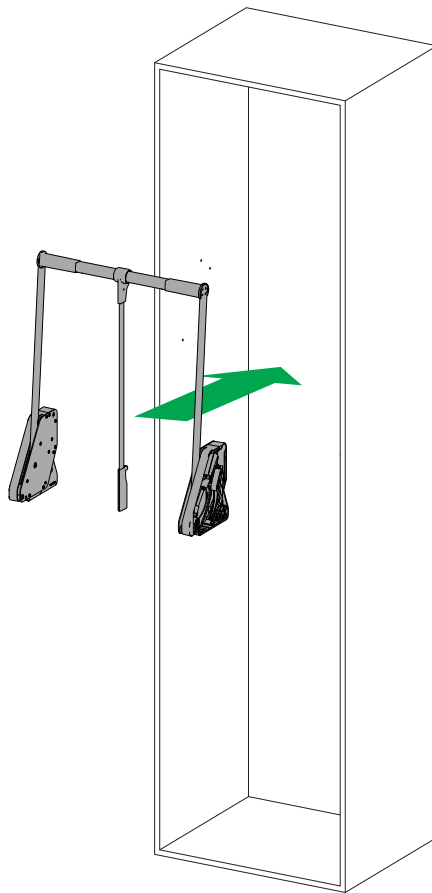
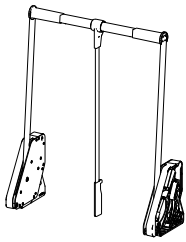

CONERO

Kleiderlift / Wardrobe lift / Tringle d'armoire escamotable



8.1

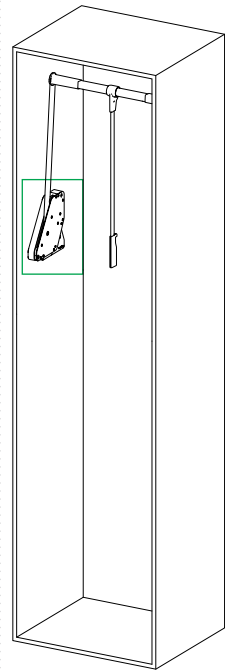
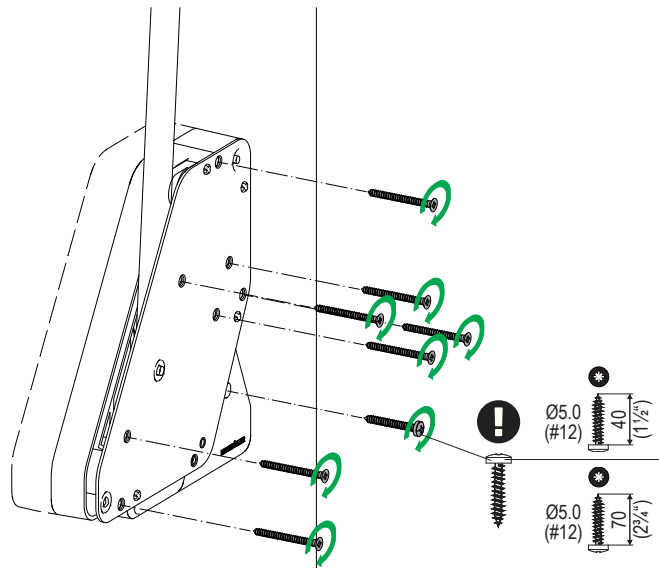
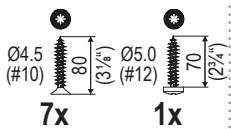
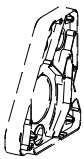
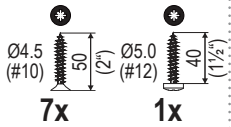

8.2

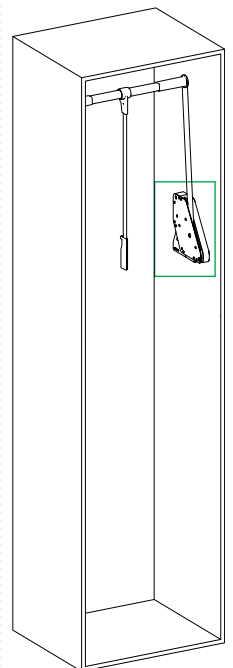
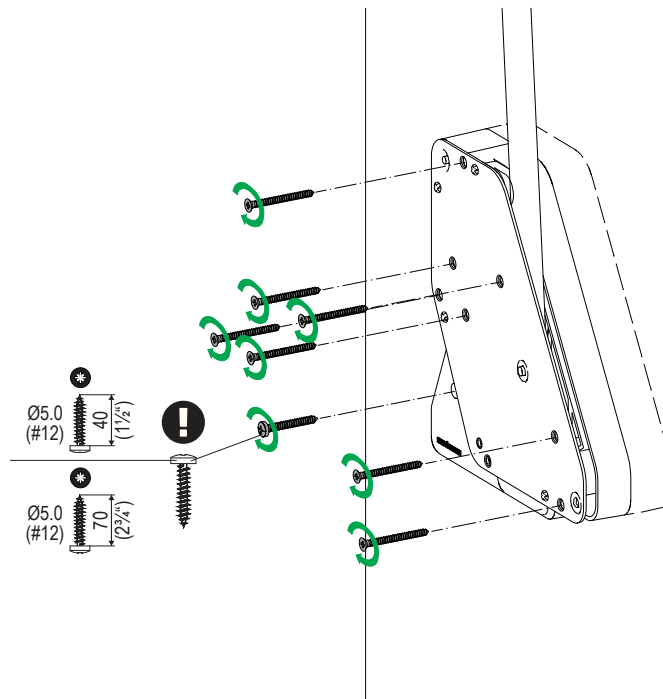
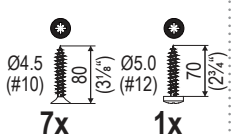
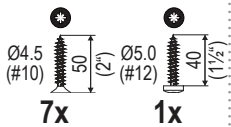

CONERO

Kleiderlift / Wardrobe lift / Tringle d'armoire escamotable



9



1x

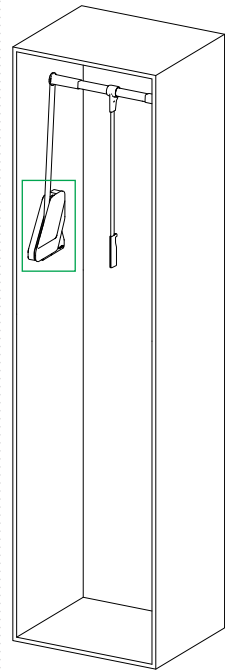
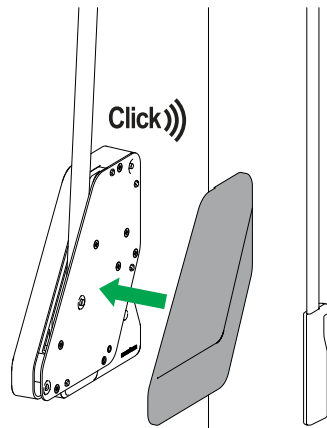

9.1



1x

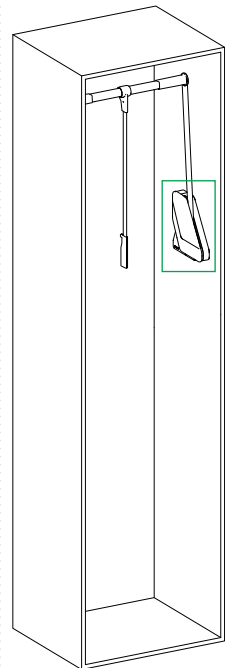
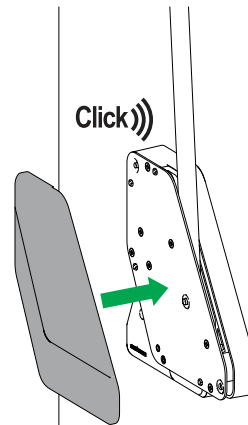

CONERO

Kleiderlift / Wardrobe lift / Tringle d'armoire escamotable



i

